

THIS DOCUMENT IS THE PROPERTY OF LYTRON, INC. AND REPRESENTS A PROPRIETARY ARTICLE ON WHICH LYTRON, INC. RETAINS ANY AND ALL PATENT AND OTHER RIGHTS, INCLUDING EXCLUSIVE RIGHTS OF USE AND/OR MANUFACTURE AND/OR SALE. POSSESSION OF THIS DOCUMENT DOES NOT CONVEY ANY PERMISSION TO REPRODUCE THE DOCUMENT OR MANUFACTURE THE ARTICLE OR ARTICLES SHOWN THEREIN.

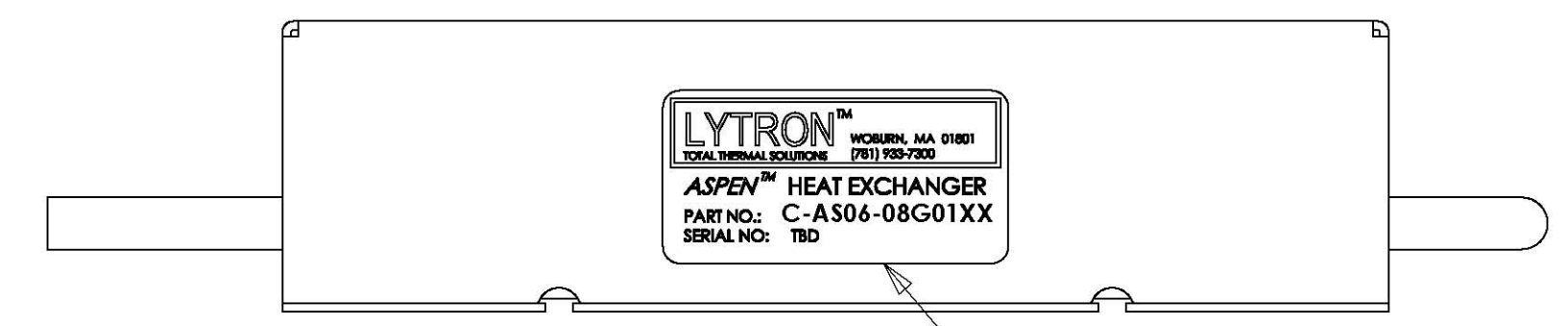
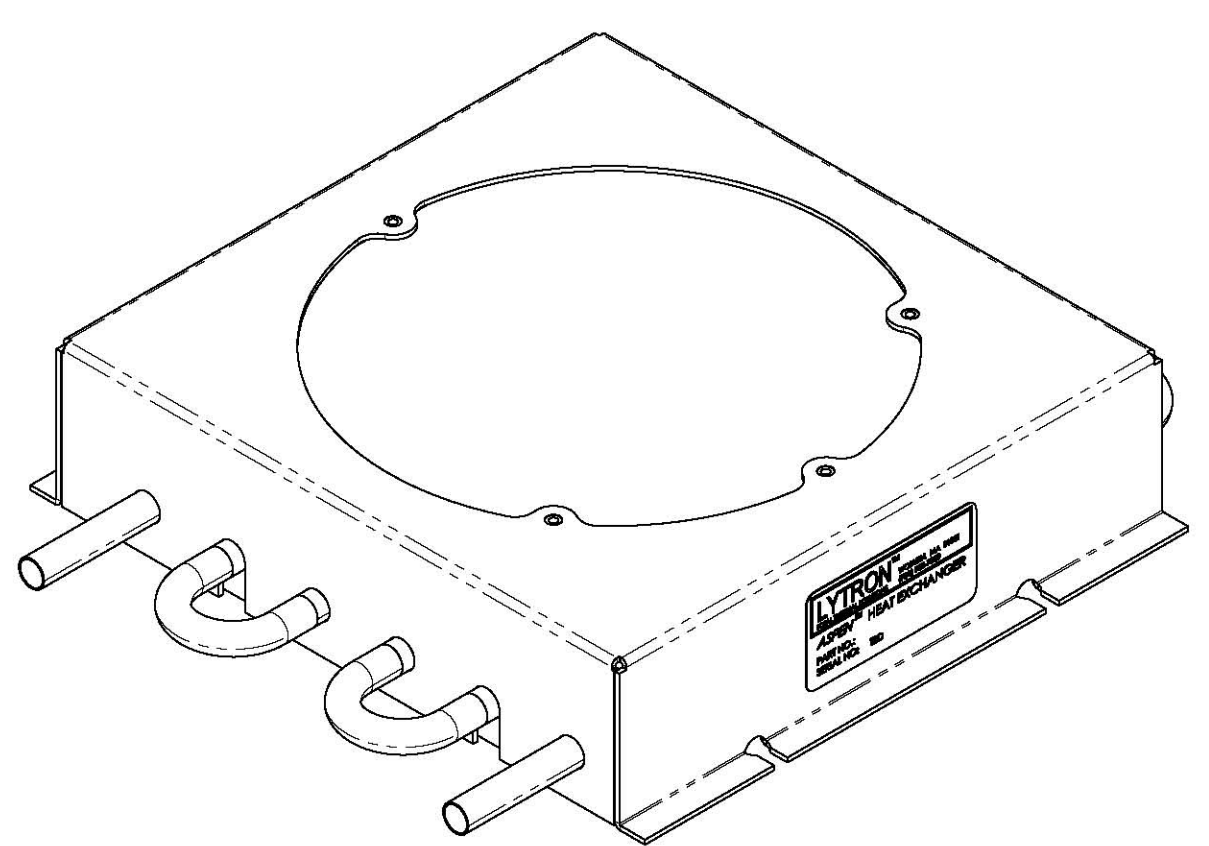
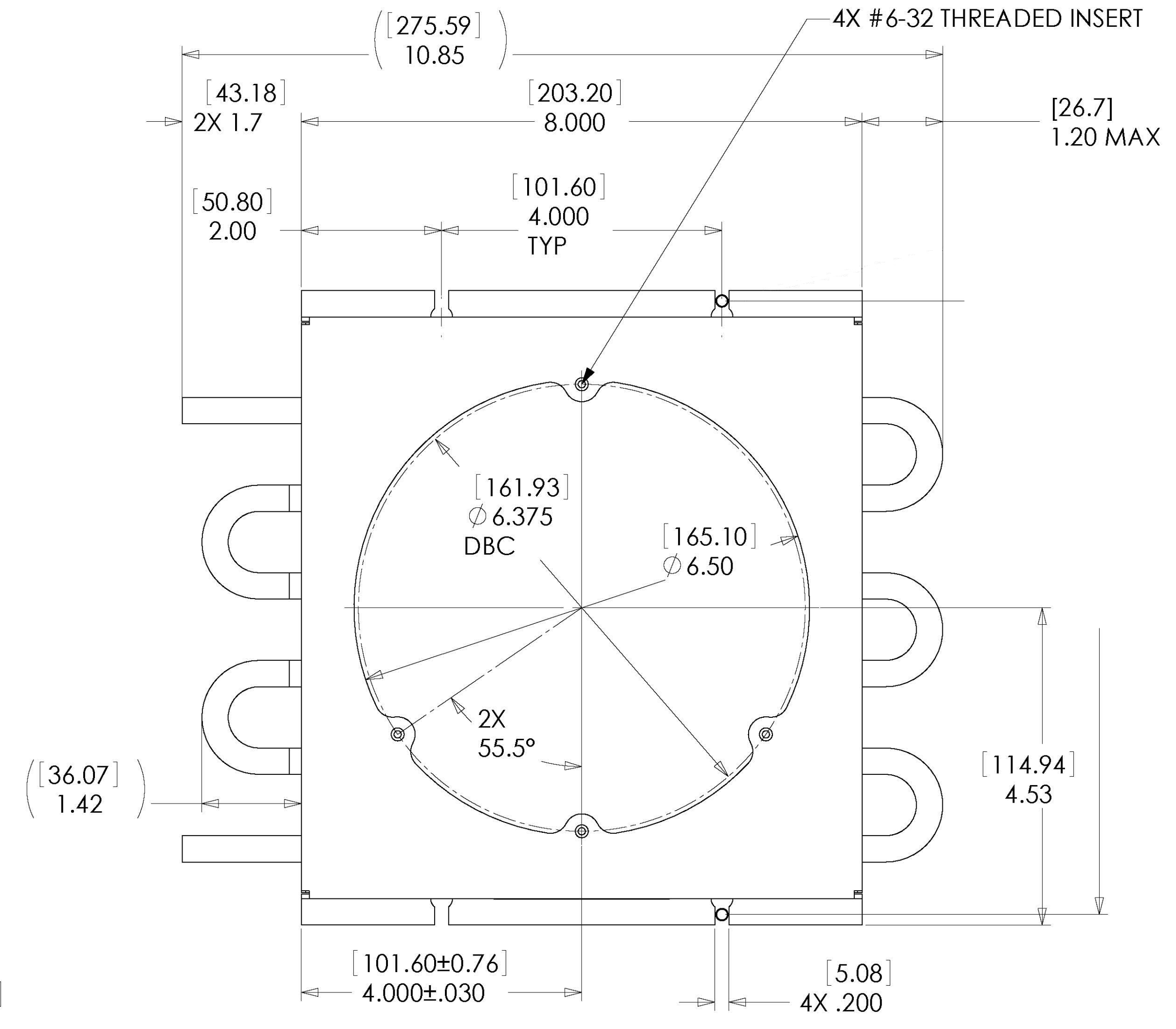
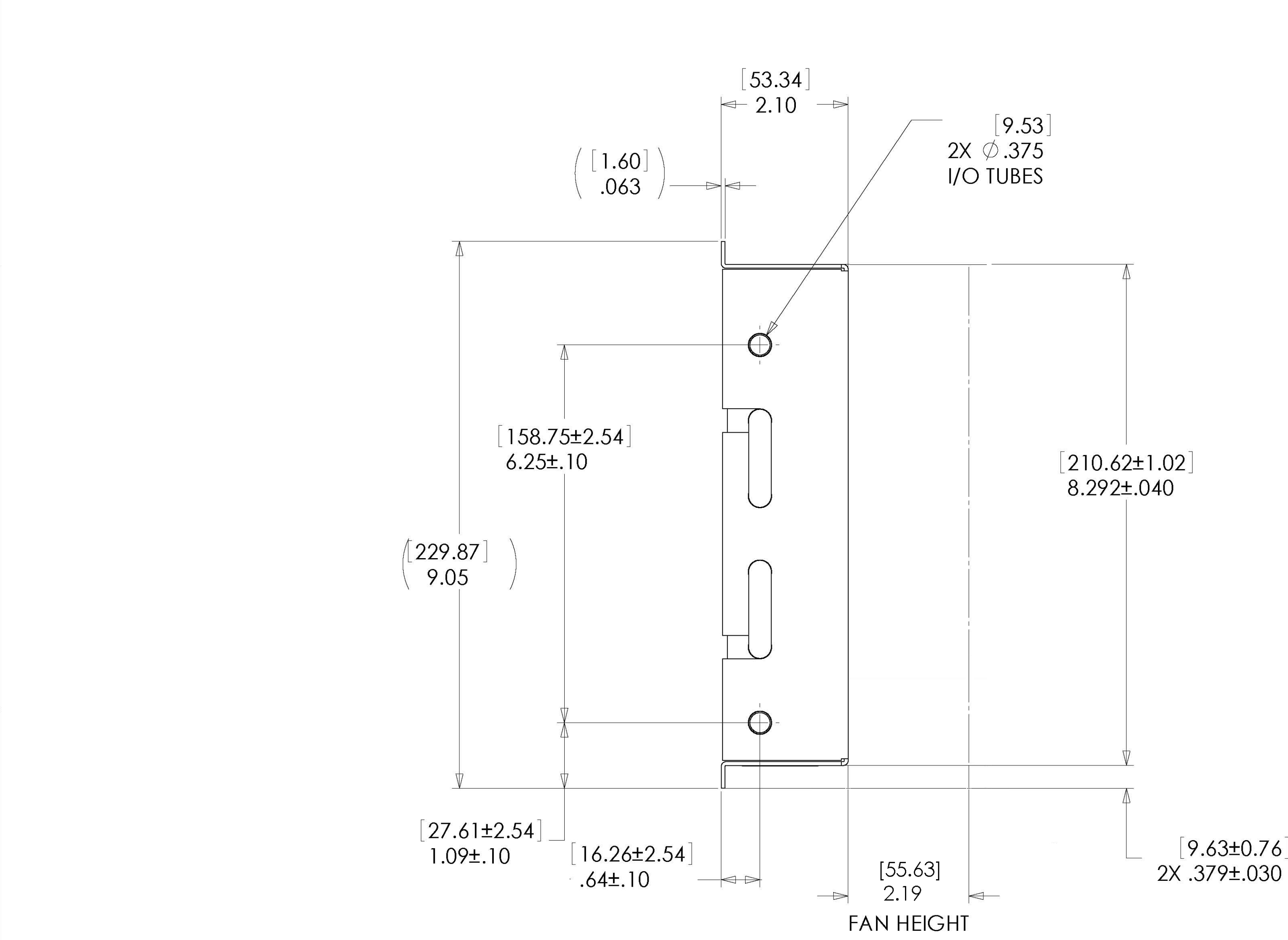

MATERIAL	
FITTINGS / TUBE	316 SS
FIN	COPPER
FRAME	ALUMINUM

LYTRON NAMEPLATE MARKED WITH P/N AND SERIAL NO LOCATED APPROX AS SHOWN

AS06-08G01SB

- NOTES:
1. PRESSURE TEST TO 150 PSIG PER LYTRON PROCEDURE 4.9.9.
 2. DIMENSIONS IN [] ARE IN MILLIMETERS

UNLESS OTHERWISE SPECIFIED		DRAWN	DATE	LYTRON INCORPORATED WOBURN, MASSACHUSETTS				
ANGULAR DIMENSIONS ± 5° SURFACE ROUGHNESS (3.2 μ) BREAK EDGES D1.0 (25mm) MAX. REMOVE ALL BURRS		CHECKED		DRAWING TITLE				
TOLERANCE ON DECIMALS		APPROVED		HEAT EXCHANGER ASSY CORE CODE: A06-01-22-07.88				
INCH ±.1 ±.06 ±.015 mm ±.005 ±.002 ±.008		APPROVED		DO NOT SCALE THIS DRAWING	SIZE	FSCM NO.	DRAWING NO.	REV
THIRD ANGLE PROJECTION		MATERIAL	SEE TABLE		D	11245	S-AS06-08G01SB	E
DIMENSIONS AND TOLERANCING ARE PER ANSI STD Y14.5		FINISH	NONE		SCALE	3/4	WT.	SHEET 1 OF 1